



英高  
EAGLESTAR



Fueling the World

# Mini/Container Fuel Station



# Company

Eaglestar, located in Zhengzhou city, Henan Province, China, is a leading manufacturer of Petroleum equipment for retail petroleum markets.

Eaglestar has been involved in the fuel dispenser industry since 2005. After over 20 years development, Eaglestar has continuously set up the sales network in Africa, Middle East and Asia markets. The high quality products and the convenient, rapid service bring a good reputation to Eaglestar. In some markets such as Nigeria, Ghana, and Tanzania. Eaglestar has been the No.1 brand and achieved over 50% market share.

In Eaglestar, innovation is the core spirit. Innovation demonstrates in research & design, production, quality-control and sales & service etc. every segment. All the electronic systems are designed and developed by Eaglestar's highly professional team. The key electronic components are imported from The US or Japan originally to keep the good quality. The mechanical hydraulic system is designed by Eaglestar team and produced by qualified OEM suppliers. The factory passed ISO9001 system.

Besides the national explosion-proof and metrology pattern approvals, Eaglestar also passed OIML testing and got the approvals. Meanwhile, the company is in the process of ATEX.

Our Goals: to maximize our market in global market. to provide the high quality products and best service for our customers.

Our vision: to be a professional manufacturer of retail petroleum equipment and solutions.

Quality management Department



## Certificate of Compliance

**Certificate Number(s):**  
UL-CA-2565775-0

**Report Reference:**  
MH67003-20251209

**Issue Date:**  
2025-12-10

Issued to:  
**Henan Eaglestar Energy Technology Co Ltd**  
The Northeast Side Of The Intersection Of No 8 Road And No 13 Road New Materials Industrial Park, Zhengzhou, Henan, 450100, CN

This certificate confirms that representative samples of:  
**EEEE7 - Aboveground Flammable-liquid Tanks Certified for Canada**

See Addendum Page for Product Designation(s).  
Have been evaluated by UL in accordance with the Standard(s) indicated on this Certificate.  
**CAN/ULC 601:2025, Edition 6, Issue Date 2025-06-27**

Additional Information:  
See UL Product IQ@ at <https://iq.ulprospector.com> for additional information.

This Certificate of Compliance indicates that representative samples of the product described in the certification report have met the requirements for UL certification. It does not provide authorization to apply the UL Mark. Only the Authorization Page that references the Follow-Up Services Procedure for ongoing surveillance provides authorization to apply the UL Mark.

Only those products bearing the UL Mark should be considered as being UL Certified and covered under UL's Follow-Up Services.

Look for the UL Certification Mark on the product.

  
 David Pieuch  
 UL Mark Certification Program Manager



Any information and documentation involving UL Mark services are provided on behalf of UL LLC (UL) or any authorized licensee of UL. For questions, please contact UL Solutions Customer Service at [info@ulprospector.com](mailto:info@ulprospector.com).  
Page 1 of 2  
© 2025 UL LLC. All rights reserved. Form:ULC601-9999-ver 1.0

CONFIDENTIAL - UL Solutions Strictly Confidential (No Encryptions)

Form QAT\_10-M05, version 02, effective since October 07th, 2022

## VERIFICATION

No. 4Q230907.HEEQ061

Verification's Holder: **Henan Eaglestar Energy Technology Co., Ltd.**  
The Northeast Side of the Intersection of No.8 Road and No.13 Road, New Materials Industrial Park, Zhengzhou, Henan

Verification ECM Mark: 

Product: **Skid-mounted gas station**  
Model(s): *(See the following annex)*

Verification to: **Standard:**  
EN IEC 60079-0:2018, EN IEC 60079-15:2019  
related to CE Directive(s):  
2014/34/EU (Equipment for Explosive Atmospheres)

 II 2 G EX n I C T6

**This document has been issued in accordance with the European Commission's note of 14 September 2022 ref. Ares (2022) 6342894 concerning voluntary certifications with non-notified procedure and for products intended for third countries outside the EU market.**

The manufacturer has voluntarily decided to submit its documents concerning the above-mentioned product for verification. Ente Certificazione Macchine confirms that the documentation made available and immediately returned to it, as containing sensitive data, meets the essential requirements of the above-mentioned directives. The verification activity carried out exclusively concerned the technical documentation and no verification was carried out on the product. This document cannot replace the EC Declaration of Conformity. The above conformity mark can be affixed to the technical documentation in accordance with the ECM regulation on its issue and use, published on the website: [www.entecerma.it](http://www.entecerma.it)

**Issuance date: 07 September 2023**  
**Expiry date: 06 September 2028**

For online check: 

Approver:  
Ente Certificazione Macchine  
Legal Representative  
Luca Barchiesi  

**Ente Certificazione Macchine Srl**  
 Via Co' Bella, 243 - Loc. Castello di Serravalle - 40053 Valsamoggia (BO) - ITALY  
 ☎ +39 051 6703141 ☎ +39 051 6703156 ✉ info@entecerma.it 🌐 www.entecerma.it

Verification - Верификация - 验证 - Verification - 증명서 - شهادة

General Administration of Quality Supervision, Inspection and Quarantine of the People's Republic of China

OIML Certificate No.  
R117/2007-CN1-17.01



## OIML CERTIFICATE OF CONFORMITY

To Henan Eaglestar Energy Technology Co., Ltd.

This certificate attests the conformity of the type of the Fuel dispenser EG5-111, EG5-212, EG5-222, EG5-424 with the requirements of the Recommendation R117 (2007) of the International Organization of Legal Metrology (OIML).

  
 The issuing authority  
 Office of OIML Affairs  
 中国秘书处  
 April 20, 2017

The CIML member  
  
 April 20, 2017





## Specification to be chosen

S/N	Model	Tank Capacity	Fuel type	Fuel product
1	EG-QY-1000	1000 Liter	1	Diesel or Gasoline
2			2	Diesel and Gasoline
3	EG-QY-2000	2000 Liter	1	Diesel or Gasoline
4			2	Diesel and Gasoline
5	EG-QY-3000	3000 Liter	1	Diesel or Gasoline
6			2	Diesel and Gasoline
7			3	Diesel and Gasoline and other
8	EG-QY-4000	4000 Liter	1	Diesel or Gasoline
9			2	Diesel and Gasoline
10	EG-QY-5000	5000 Liter	2	Diesel and Gasoline
11	EG-QY-6000	6000 Liter	2	Diesel and Gasoline
12			3	Diesel and Gasoline and other

## Main Technical Parameters

- Accuracy:  $\pm 0.30\%$
- Repeating Accuracy:  $\leq 0.15\%$
- Flow range: 5-50L/min;
- Noise:  $\leq 80\text{dB(A)}$
- IP Grade: IP54
- Humidity:  $\leq 95\%$
- Ambient Temperature:  $-25^{\circ}\text{C}\sim+55^{\circ}\text{C}$
- Atmospheric Pressure: 86kPa~106 kPa
- Unit Price range: 0-999.99
- Single range: 0-99999.99
- Accumulative range: 0-4,294,967,2.95
- Electrostatic resistance value:  $1 \times 10^3 \sim 10^6 \Omega/\text{m}$
- Pressure resistance: Fuel tank under 0.002Mpa, fuel pipe under 0.5Mpa no leakage
- Power (optional): DC24V+10%, AC110V +10%, AC 220V+10%

# Mini Fuel Station with 1 Compartment 1,000-6,000L



## Specification

- 1000-6000L Tank Capacity
- Power of AC220v,50Hz and 750w
- Hose of 4 meters long
- Flow rate of 5-50 liters
- Emergency Stop Button
- Breathing Valve
- Fuel Indicator
- Ex-proof motor

## Dimension Size

Volume	Dimension	Weight	20ft	40ft
1000L/264GAL	1700×1180×1200MM	315KG	8	20
2000L/528GAL	2100×1250×1300MM	439KG	4	10/8
3000L/792GAL	2100×1470×1630MM	540KG	4	8
4000L/1056GAL	2135×1875×1670MM	700KG	3	5
5000L/1350GAL	2600×1965×1675MM	916KG	2	4
6000L/1584GAL	3010×1960×1895MM	1865KG	1	3

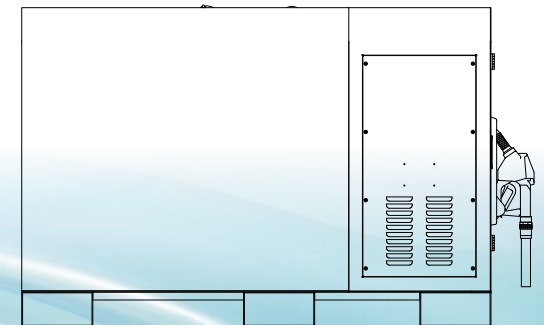
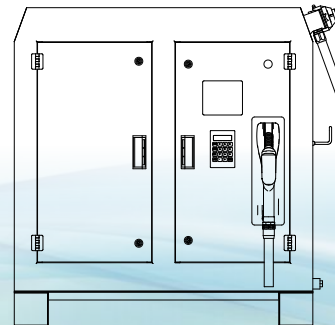

# Mini Fuel Station with 2 Compartments 2,000-6,000L



## Specification

- 2000-6000L Tank Capacity
- Power of AC220v,50Hz and 750w
- Hose of 4 meters long
- Flow rate of 5-50 liters
- Emergency Stop Button
- Breathing Valve
- Fuel Indicator
- Ex-proof motor

## Dimension Size

Volume	Dimension	Weight	20ft	40ft
2000L/528GAL	1900×1450×1620MM	439KG	4	8
3000L/792GAL	2170×1530×1810MM	540KG	3	7
4000L/1056GAL	2120×1890×1790MM	700KG	3	6
5000L/1350GAL	2560×2010×1900MM	916KG	2	4
6000L/1584GAL	2910×1900×1830MM	1865KG	2	4

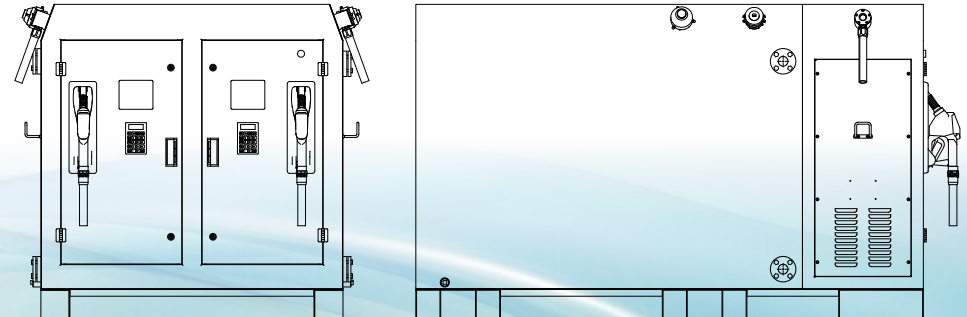

# Mini Fuel Station with 3 Compartments, 3,000L and 6,000L



## Specification

- 3000-6000L Tank Capacity
- Power of AC220v,50Hz and 750w
- Hose of 4 meters long
- Flow rate of 5-50 liters
- Emergency Stop Button
- Breathing Valve
- Fuel Indicator
- Ex-proof motor

## Dimension Size

Volume	Dimension	Weight	20ft 40ft	
			20ft	40ft
3000L/792GAL	2170×1530×1810MM	540KG	3	7
4000L/1056GAL	2120×1890×1790MM	700KG	3	6
5000L/1350GAL	2560×2010×1900MM	916KG	2	4
6000L/1584GAL	2910×1900×1830MM	1865KG	2	4

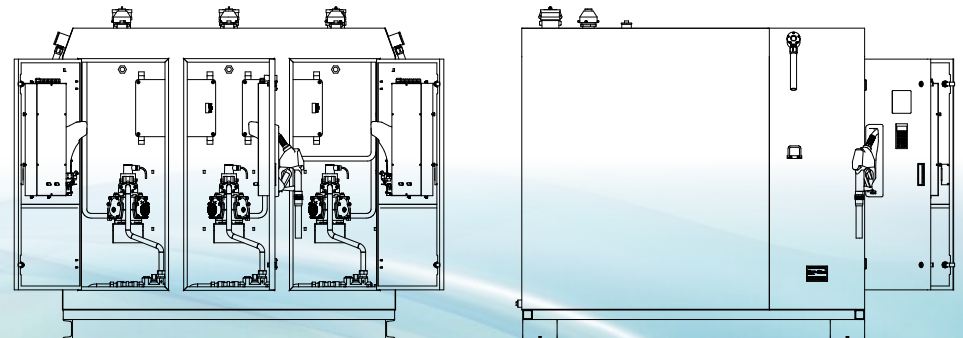

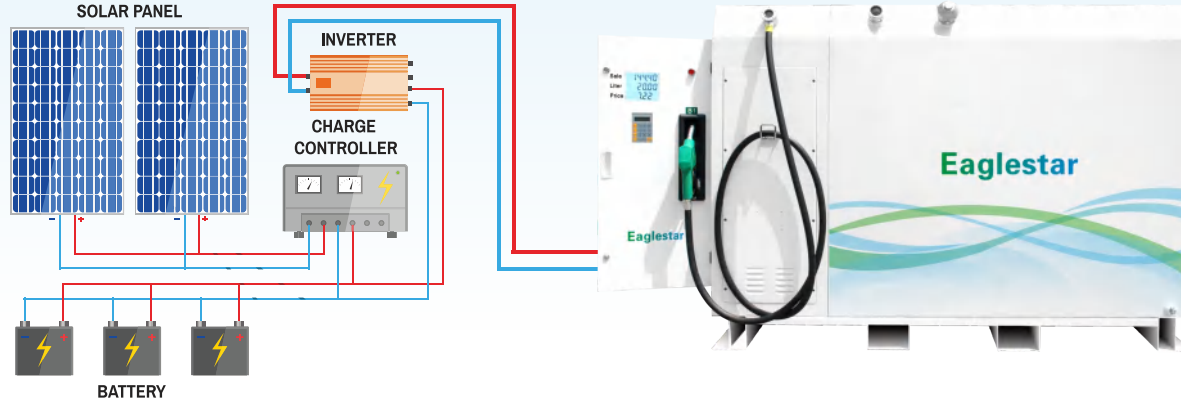

## Product Introduction

Eaglestar's integrated "Mini Fuel Station + Trailer" offers a flexible and efficient portable refueling system. It supports both fixed-site use and mobile sales to meet various fuel supply needs.



## Dimension Size

Tank Capacity	Trailer Size (L*W)	Load-bearing range
1000L	1800*1250mm	1200kg
2000L	2250*1580mm	2500kg
3000L	2250*2000mm	4100kg
4000L	2250*2000mm	4100kg
5000L	2700*2100mm	4900kg
6000L	3050*2000mm	6400kg

## Trailer Highlights

- Q235 Steel Structure: Strong, durable, high load capacity
- Vacuum Tires : Wear-resistant, anti-burst
- Brake System: Reliable mechanical parking brake
- Stable Towing: Triangular design, stable connection
- Steady Parking: 4 mechanical legs for steady parking
- Night Visibility: Tail lights & 7-pin socket for night safety



# Container Fuel Station 10,000L-20,000L

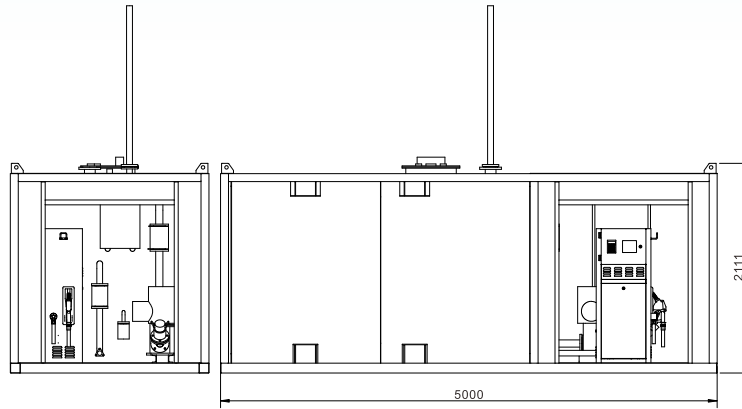
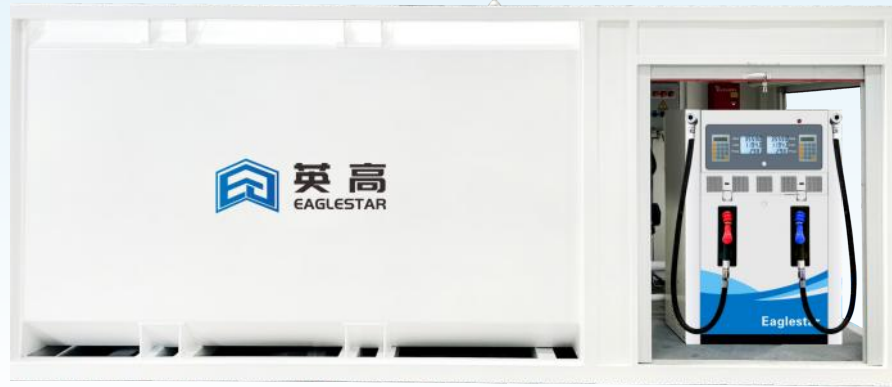

10000L

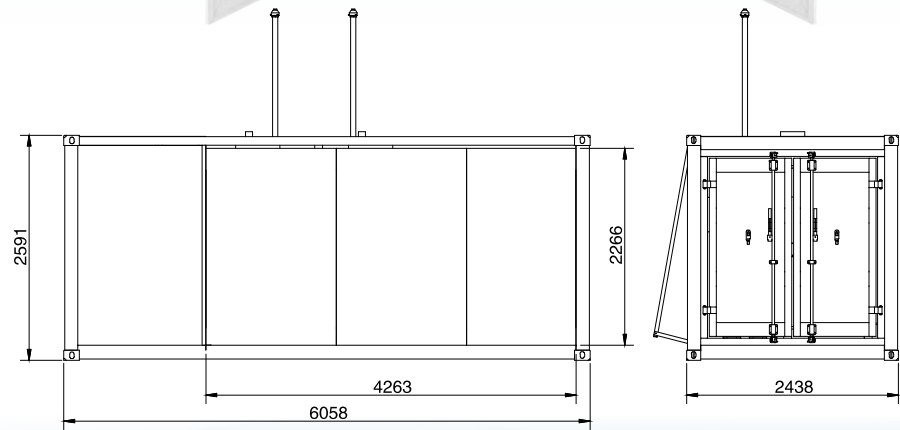

20000L

## Dimension Size

Model	Total volum(Liters)	Container inner size(mm)	Total weight(ton)
20GP	10 000 / 2640GAL	5000x2000x2111	4.23
	20 000 / 5280GAL	6058x2438x2590	4.93

# Container Fuel Station 30,000L-60,000L

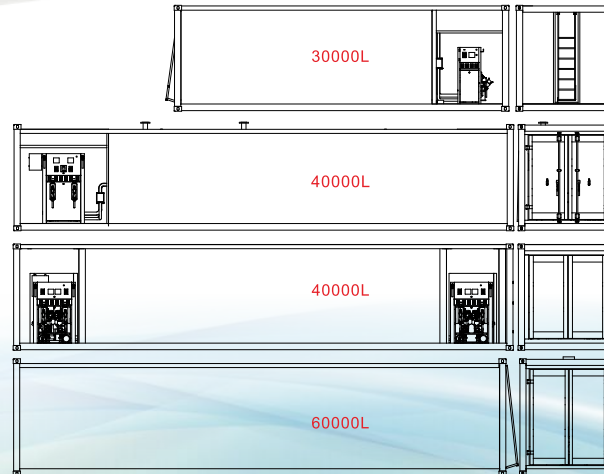

## Dimension Size

Model	Total volum(Liters)	Container inner size(mm)	Total weight(ton)
40GP	30 000 / 7920GAL <small>(fuel dispenser outside)</small>	8020x2424x2536	6.95
	36 000 / 9504GAL	12029x2350x2390	7.25
	40 000 / 10560GAL	12192x2438x2591	7.75
40HP	50 000 / 13200GAL	12029x2350x2697	8.39
	55 000 / 14520GAL	12029x2350x2697	9.35
	60 000 / 16368GAL <small>(fuel dispenser outside)</small>	12192x2438x2896	10.31



Fuel Tank 75,000 L



Tank Farm

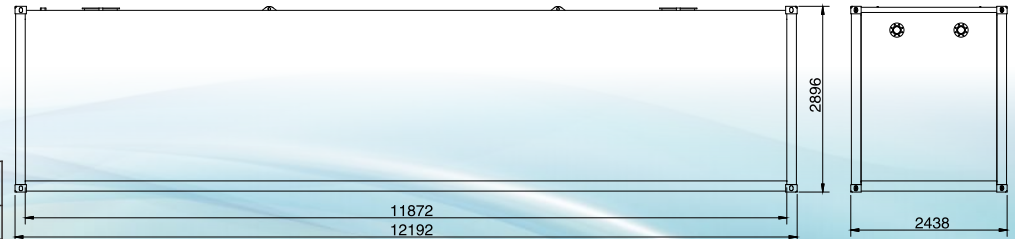

Dimension Size

Model	Total volum(Liters)	Container inner size(mm)	Total weight(ton)
40ft	70 000 / 18518GAL	12192x2438x2896	11.27

# Container Fuel Station Sketch-1

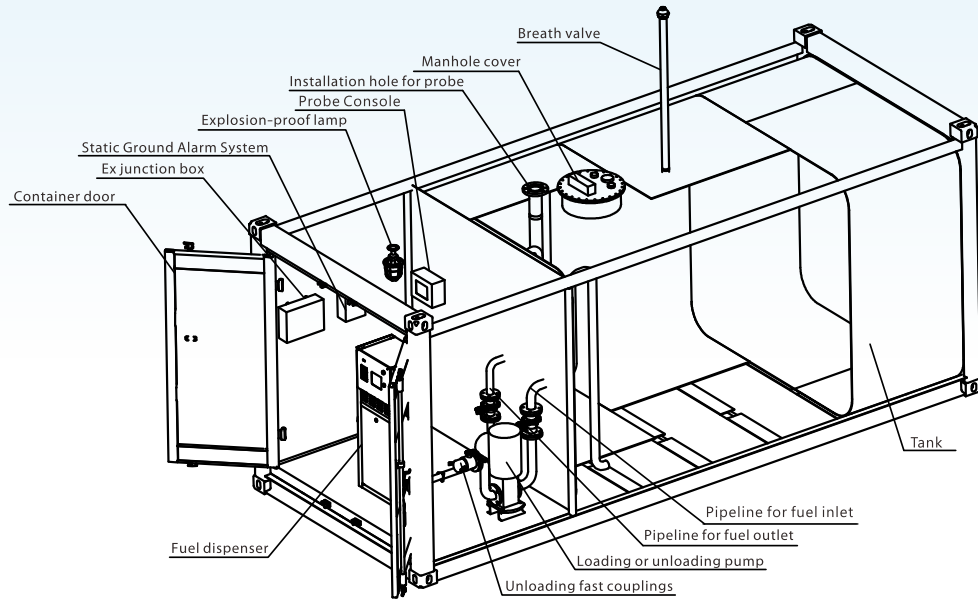

## Standard configuration :

- Standard ISO Containers 20ft, 40ft, 40HQ
- Certified Storage Tank ( NB/T47003.1-2009) equivalent to EN12285-2
- Single / Double Wall Storage Tank
- CSC certificate for exportation
- OIML Certified Dispenser / Pump
- 50 / 70 / 120 LPM flow rate
- 1 or 2 or 3 compartments
- Alarm Systems
- Explosion proof Illumination
- Explosion proof Junction Electric Box
- Vent valve
- Manhole
- Steel Piping
- Unloading piping, valves and couplings
- Loading piping, valves and couplings
- Oil dip stick
- Mechanic level gauge
- Fire extinguisher
- 24V or 220V explosion proof motor

## Options :

- Leak detector for double wall
- Diesel Generator
- Operator room / office
- Fuel Filtration
- Drain valve
- Sight glass
- Automatic Tank Gauging
- PV anti fire relief valve
- Combustible gas detector
- Check valve
- Rolling shutter door
- Integrated ladder

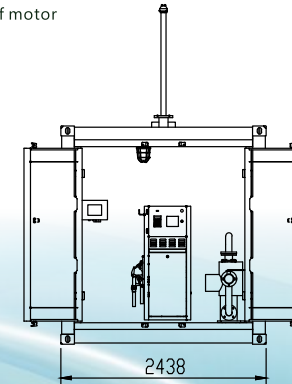
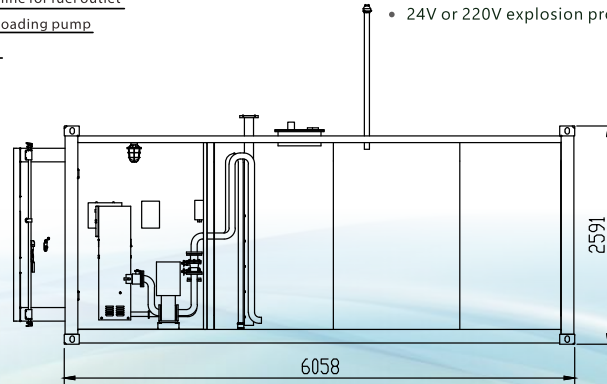
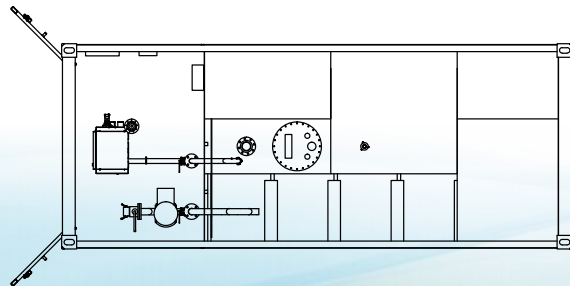

# Container Fuel Station Sketch-2

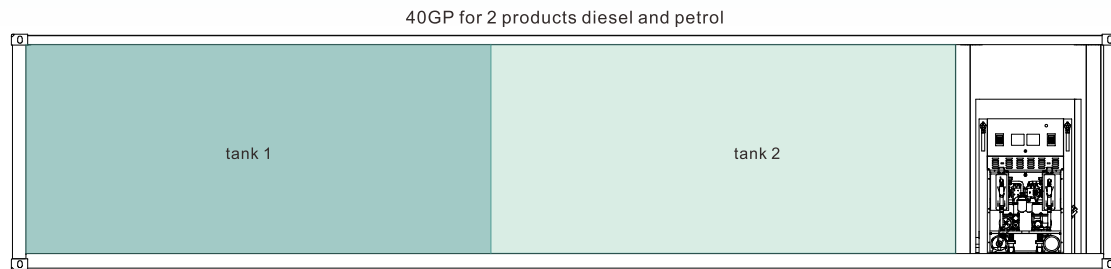
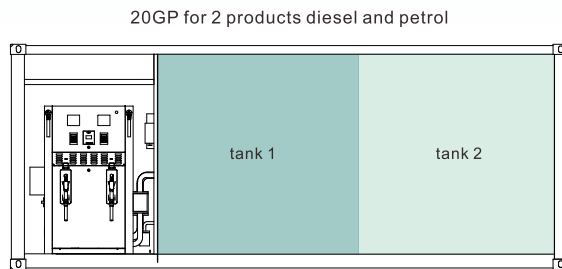
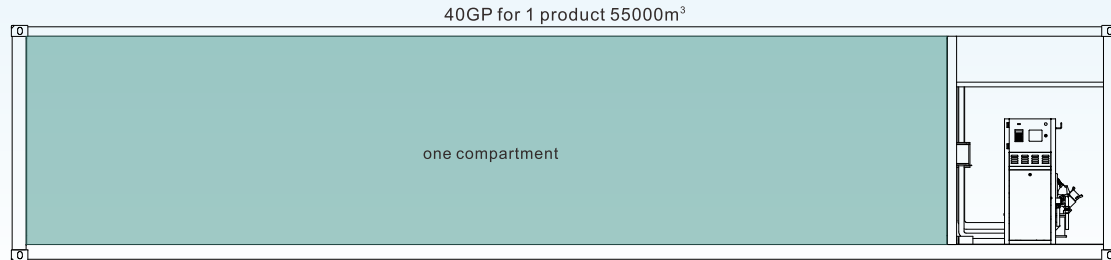
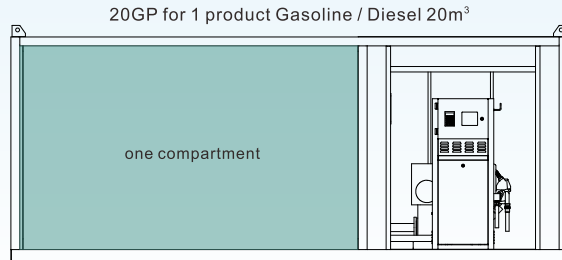

Total volum(Liters)	Layer /Compartment
10 000 / 7920GAL	<ul style="list-style-type: none"> <li>• Tank compartment: one or two or three (Diesel, Petrol, Other type of fuel)</li> <li>• Layers of tank: single or double</li> <li>• Pump Island: one or two</li> <li>• Fuel dispenser: one unit or two units, single nozzle or two nozzles three nozzles</li> </ul>
20 000 / 9504GAL	
30 000 / 10560GAL	
40 000 / 13200GAL	
50 000 / 14520GAL	
60 000 / 16368GAL	

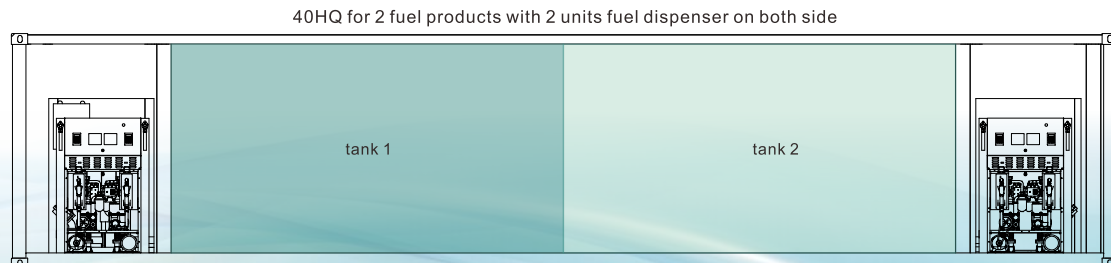

# Components Description

## Default configuration

Unloading fast couplings



Ball valve



Manhole cover



Load or unloading pump



Breath valve



Static Release System



Ex junction box



Explosion-proof lamp



Console



Probe

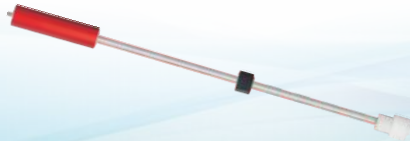

## Optional Part

Double tank leak detector



Diesel generator



Petro Card



Printing



Solar Support



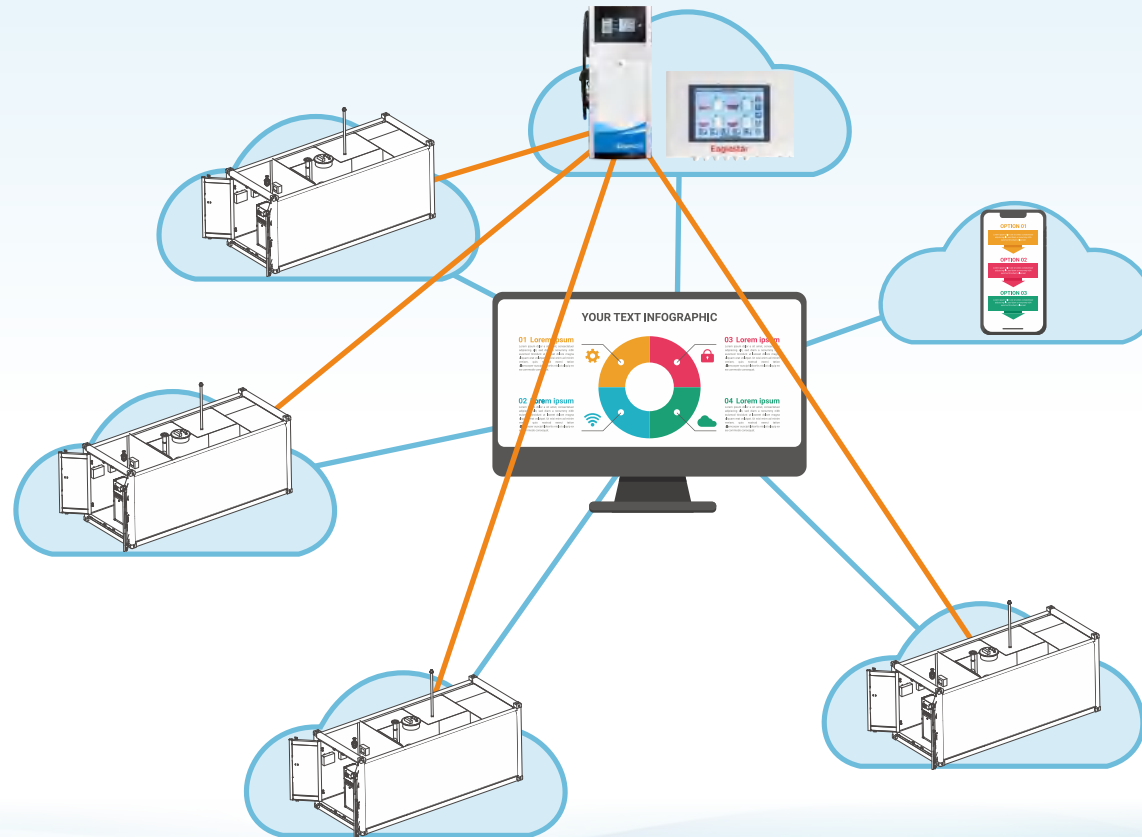

4G/5G module on fuel dispenser and tank level gauge controller can transmit the sales and tank stock data via GPRS easily. You can easily check all the data by daily, monthly or yearly. All the fuel business are controlled well.

# Container Fuel Station RFID Refueling Solution

**Option 2**

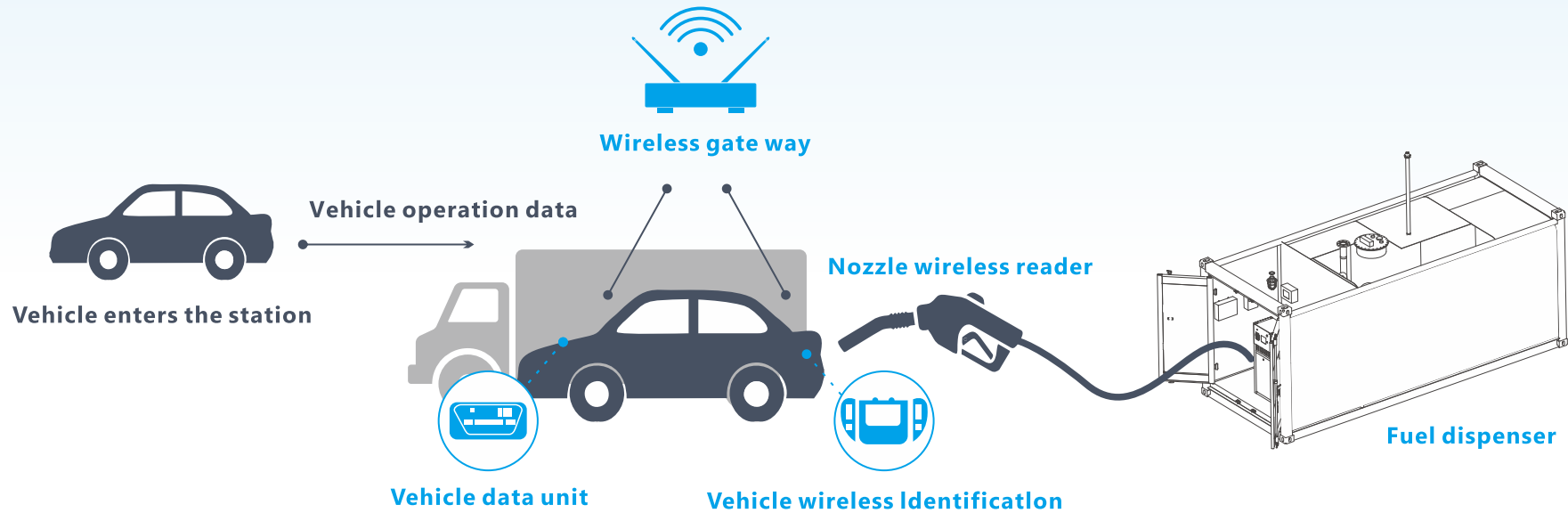

1. Establish the link between nozzles and vehicles automatically Improve customer loyalty
2. Safe and reliable, specially developed for gas stations, reduce gas station operation cost

Fueling Station Show-1



## Fueling Station Show-2



Fueling Station Show-3



Fueling Station Show-4





## Henan Eaglestar Energy Technology Co., Ltd

Add: No 8, the 5th Diamond Rd, Zhengzhou New Materials Park, Zhengzhou city, Henan Province, China.

Whatsapp&Viber: 008613598081203 Email: sales@eaglestarpetro.com

[www.chinaeaglestar.com](http://www.chinaeaglestar.com) / [www.egfueldispenser.com](http://www.egfueldispenser.com) / [www.eaglestarenergy.com](http://www.eaglestarenergy.com)